

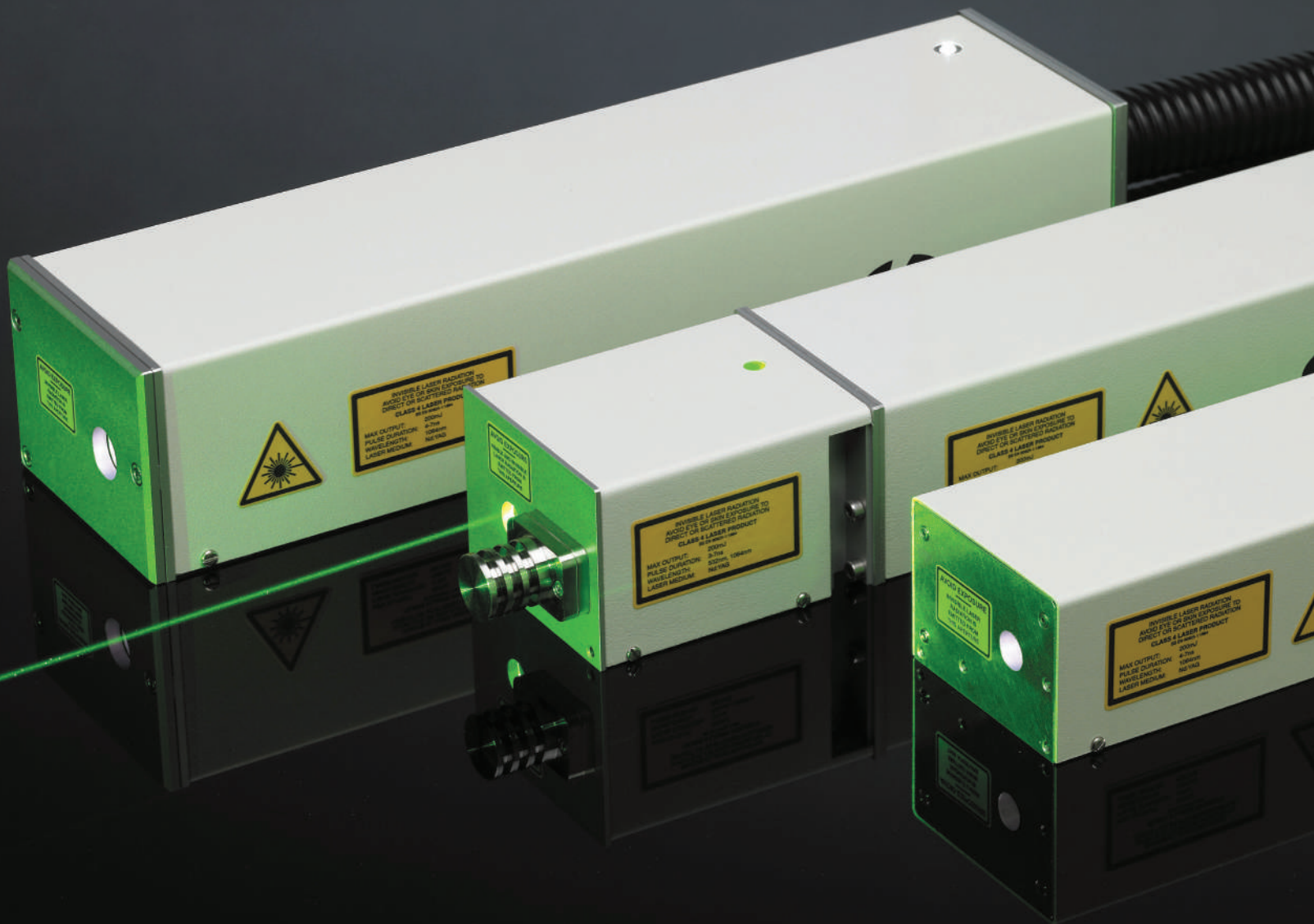

NANO SERIES

Ultra-Compact, Rugged, Q-Switched Nd:YAG Lasers

2 0 2 0



Nano Series

Ultra-compact, rugged Q-switched pulsed Nd:YAG lasers

APPLICATIONS

- **LIBS & Spectroscopy**
- **LIDAR & Remote sensing**
- **Sensor diagnostics**
- **Metrology**
- **Material processing**
- **Ablation**
- **Pump source**
- **Photochemistry**
- **Non linear optics**
- **Ultrasonic testing**
- **Flash photolysis**
- **LIF & ESPI**

There are three laser heads in the Nano series: the Nano S, the Nano L and the Nano T. All three laser heads are fundamentally the same in terms of construction: they are all machined from a solid block of aluminium, have electronic intra-cavity safety shutters, fully sealed Pockels cells, stainless steel close-coupled pumping chambers and easily adjustable mirrors and optics.

The design of the Nano range facilitates the connection of any power supply to any head. This benefits the customer both in terms of size and cost of the laser, as the system provided will be optimally tailored to the requirements of the customer.

THE NANO S

The Nano S is one of the smallest 'end user' laser systems of its type in the world with a footprint of just 292mm x 82mm, with energies of up to 150mJ per pulse and repetition rates of up to 50Hz. The Nano S can be configured with a stable or super-Gaussian resonator, and can be fitted with an intra-cavity aperture to give a true TEM₀₀ output.

THE NANO L

The Nano L has a footprint of only 380mm x 96mm. Output energies of up to 340mJ and repetition rates of up to 100Hz are available. The Nano L can be supplied with either a stable or super-Gaussian resonator. If required, a removable intra-cavity aperture can also be fitted to give a true TEM₀₀ output.

THE NANO T

The Nano T has a footprint of 520mm x 96mm. Output energies of up to 290mJ and repetition rates of up to 50Hz are available. The Nano T is configured as a stable telescopic resonator, and can be fitted with a removable intra-cavity aperture to give a true TEM₀₀ output.



LUCi Touchscreen

FEATURES

- **Output energies up to 340mJ**
- **Repetition rates up to 100Hz**
- **2nd, 3rd, 4th and 5th harmonics available**
- **Fully motorised optical attenuator**
- **Fully interlocked electrical safety shutter**
- **LUCi touchscreen or PC interface**
- **Stable, stable telescopic or super-Gaussian coupled resonator**
- **Compact and rugged**
- **TEM₀₀ option available**
- **Long flashlamp lifetime and easy replacement**
- **Air-cooled PSU (internal water)**



Resonator Types

Litron offers five distinct resonator configurations, more than any other manufacturer. The information below can be used to identify which resonator is best suited to an application.

A. Stable

This multimode resonator gives excellent energy extraction and beam uniformity but somewhat high divergence and M^2 values. Stable resonators allow the user to alter parameters such as input energy (flashlamp voltage) and repetition rate with very little variation in beam quality.

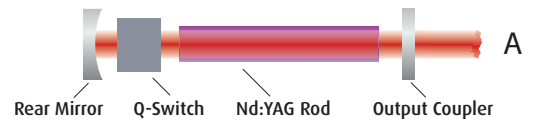

B. Stable Telescopic

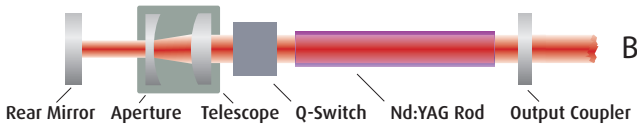

This variation on the multimode stable design places an intracavity telescope in the rear of the resonator. This has two effects of compensating for thermal lensing in the laser rod and making the resonator appear considerably longer, without making it significantly more so, meaning reasonably short pulses are still obtained. The outcome is a laser beam with very good spatial uniformity and efficient energy extraction but with much better divergence and M^2 characteristics than a conventional stable resonator. The resonator is still flexible in terms of input energy and repetition rate and can be made even more so by means of adjustments to the telescope.

C. Gaussian-Coupled Unstable

This resonator comprises a P-branch confocal unstable resonator with a graded reflectivity mirror (GRM) for the output coupler. The GRM unstable resonator provides lower values still for divergence and M^2 , with reasonable extraction efficiency but the downside is less uniform near field uniformity and much less flexibility in varying the input energy and repetition frequency.

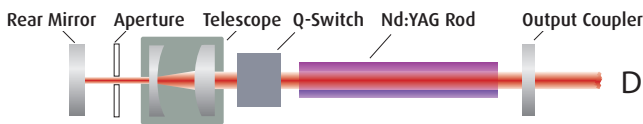
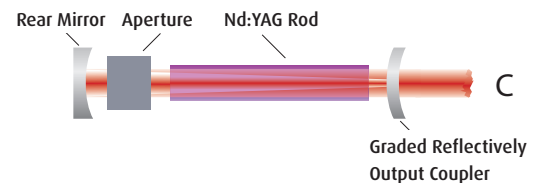

D. Stable Telescopic TEM₀₀

This is a variation on the stable telescopic resonator that additionally employs an intracavity aperture to suppress higher order transverse modes resulting in a beam with near diffraction limited, single mode TEM₀₀ quality, with a uniform Gaussian profile.

E. Stable TEM₀₀

Compared to a stable telescopic TEM₀₀ laser, a smaller footprint, shorter pulse duration and greater input energy flexibility are the main benefits. However, lacking the telescope, the extraction efficiency is lower.

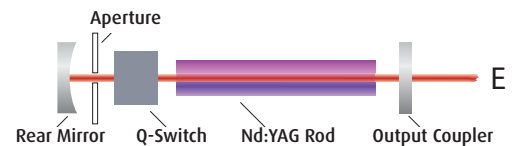

Nano Uncovered

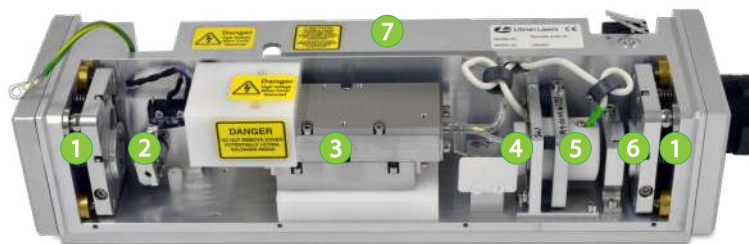

1 MIRROR MOUNTS

- High precision stable mirror mounts locked in position to prevent any alignment change.

2 INTERLOCKED ELECTRONIC SAFETY SHUTTER

- To prevent the laser being started with the shutter open.

3 PUMPING CHAMBER

- Two extremely close coupled ceramic reflectors ensure uniform pumping of the laser rod.
- Simple flashlamp replacement.

4 POLARISER

5 POCKELS CELL

- KD*P crystal sealed in a rugged housing.

6 QUARTER-WAVE PLATE

7 RESONATOR HOUSING

- Machined from a solid piece of aluminium ensuring exceptional mechanical rigidity and thermal stability.

TECHNICAL DATA

Stable Resonator Nano S

Model	Nano S 130-10	Nano S 120-20	Nano S 60-30	Nano S 30-50
Max Repetition Rate (Hz)	10	20	30	50
Output Energy (mJ) ⁽¹⁾				
1064nm	130	120	60	30
532nm	65	60	30	15
355nm	25	15	10	6
266nm	16	12	6	3
213nm	3	3	2	1
Parameter				
Pulse - Pulse Stability ($\pm\%$) ⁽²⁾	2	2	2	2
Beam Diameter (mm)	4	4	4	4
Beam Divergence (mrad) ⁽³⁾	<2.5	<2.5	<2.0	<2.0
Pulse Length @ 1064nm (ns)	4-7	4-7	4-7	4-7
Pointing Stability (μ rad) ⁽⁴⁾	<70	<70	<70	<70
Resonator Type	Stable	Stable	Stable	Stable
TEM ₀₀ (mJ) @ 1064nm ⁽⁵⁾	10	10	8	8
Lamp Life (pulses)	5x10 ⁷	5x10 ⁷	5x10 ⁷	5x10 ⁷
Timing Jitter (ns) ⁽⁶⁾	<0.5	<0.5	<0.5	<0.5
Services				
Voltage (VAC)	90-250	90-250	90-250	90-250
Frequency (Hz)	47-63	47-63	47-63	47-63
Power	Single Phase	Single Phase	Single Phase	Single Phase
Ambient ($^{\circ}$ C) ⁽⁷⁾	5-35	5-35	5-35	5-35
Consumption (W)	<300	<300	<300	<300
PSU Type	LPU350 ⁽⁸⁾	LPU350 ⁽⁸⁾	LPU350 ⁽⁸⁾	LPU350 ⁽⁸⁾

(1) Variable by means lamp voltage control. The maximum energy is quoted for a system having a 15 minute warm-up period.

(2) At 1064nm.

(3) Irreducible beam divergence measured full angle for cone containing 90% of energy.

(4) Full angle for 99% of shots.

(5) With the addition of optional intra-cavity aperture. Factory fitted option on the Nano S range, this is not retrofittable. On the Nano L range the TEM₀₀ aperture can be added or removed.

(6) RMS jitter, measured with respect to the Q-switch trigger input.

(7) 0-80% non condensing atmosphere.

(8) LPU350R option available as 4U 19" rackmountable PSU.

(9) 90-250VAC available on request. LPU1000R option available as 7U 19" rackmountable PSU.

Stable Resonator Nano L

Model	Nano L 340-10	Nano L 200-10	Nano L 290-20	Nano L 200-20	Nano L 200-30	Nano L 150-50	Nano L 90-100
Max Repetition Rate (Hz)	10	10	20	20	30	50	100
Output Energy (mJ) ⁽¹⁾							
1064nm	340	200	290	200	200	150	90
532nm	200	110	145	110	110	75	50
355nm	45	40	50	40	40	30	15
266nm	30	25	30	25	25	15	10
213nm	5	4	5	3	3	3	2
Parameter							
Pulse - Pulse Stability ($\pm\%$) ⁽²⁾	2	2	2	2	2	2	2
Beam Diameter (mm)	6.5	6.5	6.5	6.5	6.5	6.5	6.5
Beam Divergence (mrad) ⁽³⁾	<2.0	<2.0	<2.0	<2.0	<2.0	<2.0	<2.0
Pulse Length @ 1064nm (ns)	7-9	6-9	7-9	6-9	6-9	7-9	7-9
Pointing Stability (μ rad) ⁽⁴⁾	<70	<70	<70	<70	<70	<70	<70
Resonator Type	Stable	Stable	Stable	Stable	Stable	Stable	Stable
TEM ₀₀ (mJ) @ 1064nm ⁽⁵⁾	20	20	20	20	20	20	20
Lamp Life (pulses)	5x10 ⁷	5x10 ⁷	5x10 ⁷	5x10 ⁷	5x10 ⁷	5x10 ⁷	5x10 ⁷
Timing Jitter (ns) ⁽⁶⁾	<0.5	<0.5	<0.5	<0.5	<0.5	<0.5	<0.5
Services							
Voltage (VAC)	90-250	90-250	220-250	90-250	220-250	220-250	220-250
Frequency (Hz)	47-63	47-63	47-63	47-63	47-63	47-63	47-63
Power	Single Phase	Single Phase	Single Phase	Single Phase	Single Phase	Single Phase	Single Phase
Ambient ($^{\circ}$ C) ⁽⁷⁾	5-35	5-35	5-35	5-35	5-35	5-35	5-35
Consumption (W)	<350	<350	<450	<650	<650	<850	<850
PSU Type	LPU350 ⁽⁸⁾	LPU350 ⁽⁸⁾	LPU1000 ⁽⁹⁾	LPU350 ⁽⁸⁾	LPU1000 ⁽⁹⁾	LPU1000 ⁽⁹⁾	LPU1000 ⁽⁹⁾

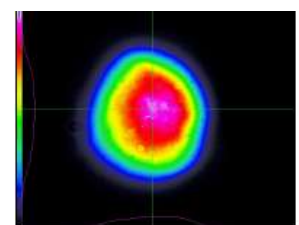

Stable beam profile, 1064nm near field

Super-Gaussian Coupled Resonator - Nano SG

Model	Nano SG 150-10	Nano SG 120-20	Nano SG 60-30
Max Repetition Rate (Hz)	10	20	30
Output Energy (mJ) ⁽¹⁾			
1064nm	150	120	60
532nm	75	65	35
355nm	30	15	10
266nm	15	12	6
213nm	3	2	1
Parameter			
Pulse - Pulse Stability ($\pm\%$) ⁽²⁾	2	2	2
Beam Diameter (mm)	5	4	4
Beam Divergence (mrad) ⁽³⁾	<0.7	<0.5	<0.5
Fit to Gaussian N/F field (%)	70/95	70/95	70/95
M ²	<2	<2	<2
Pulse Length @ 1064nm (ns)	4-6	6-8	6-8
Pointing Stability (μ rad) ⁽⁴⁾	<70	<70	<70
Lamp Life (pulses)	5x10 ⁷	5x10 ⁷	5x10 ⁷
Timing Jitter (ns) ⁽⁵⁾	<0.5	<0.5	<0.5
Services			
Voltage (VAC)	90-250	90-250	90-250
Frequency (Hz)	47-63	47-63	47-63
Power	Single Phase	Single Phase	Single Phase
Ambient ($^{\circ}$ C) ⁽⁶⁾	5-35	5-35	5-35
Consumption (W)	<350	<350	<350
PSU Type	LPU350 ⁽⁷⁾	LPU350 ⁽⁷⁾	LPU350 ⁽⁷⁾

- (1) Variable by means of Q-switch delay.
The maximum energy is quoted for a system having a 15 minute warm-up period.
- (2) At 1064nm.
- (3) Irreducible beam divergence measured full angle for cone containing 90% of energy.
- (4) Full angle for 99% of shots.
- (5) RMS jitter, measured with respect to the Q-switch trigger input.
- (6) 0-80% non condensing atmosphere.
- (7) LPU350R option available as 4U 19" rackmountable PSU.
- (8) 200VAC available on request.
LPU1000R option available as 7U 19" rackmountable PSU.

Super Gaussian Coupled Resonator - Nano LG

Model	Nano LG 300-10	Nano LG 225-10	Nano LG 250-20	Nano LG 200-20	Nano LG 150-30	Nano LG 130-50
Max Repetition Rate (Hz)	10	10	20	20	30	50
Output Energy (mJ) ⁽¹⁾						
1064nm	300	225	250	200	150	130
532nm	150	120	125	110	75	65
355nm	60	50	45	40	25	20
266nm	35	30	30	25	18	15
213nm	6	5	5	4	2	2
Parameter						
Pulse - Pulse Stability ($\pm\%$) ⁽²⁾	2	2	2	2	2	2
Beam Diameter (mm)	5	5	5	5	5	5
Beam Divergence (mrad) ⁽³⁾	<0.7	<0.5	<0.7	<0.5	<0.5	<0.5
Fit to Gaussian N/F field (%)	70/95	70/95	70/95	70/95	70/95	70/95
M ²	<2	<2	<2	<2	<2	<2
Pulse Length @ 1064nm (ns)	4-6	4-6	4-6	4-6	4-6	4-6
Pointing Stability (μ rad) ⁽⁴⁾	<100	<70	<100	<70	<100	<100
Lamp Life (pulses)	5x10 ⁷	5x10 ⁷	5x10 ⁷	5x10 ⁷	5x10 ⁷	5x10 ⁷
Timing Jitter (ns) ⁽⁵⁾	<0.5	<0.5	<0.5	<0.5	<0.5	<0.5
Services						
Voltage (VAC)	220-250	220-250	220-250	220-250	220-250	220-250
Frequency (Hz)	47-63	47-63	47-63	47-63	47-63	47-63
Power	Single Phase	Single Phase	Single Phase	Single Phase	Single Phase	Single Phase
Ambient ($^{\circ}$ C) ⁽⁶⁾	5-35	5-35	5-35	5-35	5-35	5-35
Consumption (W)	<650	<650	<650	<650	<650	<650
PSU Type	LPU1000 ⁽⁸⁾	LPU350 ⁽⁷⁾	LPU1000 ⁽⁸⁾	LPU350 ⁽⁷⁾	LPU1000 ⁽⁸⁾	LPU1000 ⁽⁸⁾

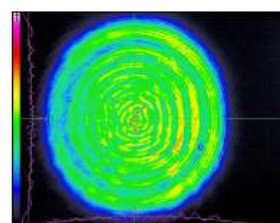

Super-Gaussian beam profile,
1064nm near field

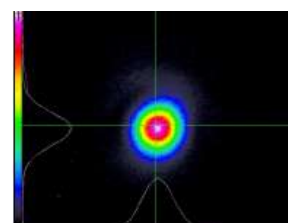

Super-Gaussian beam profile,
1064nm far field

TECHNICAL DATA

Stable Telescopic Resonator Nano T

Model	Nano T 290-10	Nano T 250-10	Nano T 270-20	Nano T 250-20	Nano T 100-50
Max Repetition Rate (Hz)	10	10	20	20	50
Output Energy (mJ) ⁽¹⁾					
1064nm	290	250	270	250	100
532nm	145	125	135	125	50
355nm	50	45	45	45	20
266nm	27	30	25	30	15
213nm	4	4	3	4	2
Parameter					
Pulse - Pulse stability ($\pm\%$) ⁽²⁾	2	2	2	2	2
Beam Diameter (mm)	6.35	5	5	5	5
Beam Divergence (mrad) ⁽³⁾	<0.8	<0.8	<0.8	<0.8	<0.8
Pulse Length @ 1064nm (ns)	7-11	7-11	7-11	7-11	7-11
Pointing Stability (μ rad) ⁽⁴⁾	<70	<70	<70	<70	<70
Resonator Type	Telescopic	Telescopic	Telescopic	Telescopic	Telescopic
TEM ₀₀ (m) @ 1064nm ⁽⁵⁾	40	40	40	40	25
Lamp Life (pulses)	5x10 ⁷	5x10 ⁷	5x10 ⁷	5x10 ⁷	5x10 ⁷
Timing Jitter (ns) ⁽⁶⁾	<0.5	<0.5	<0.5	<0.5	<0.5
Services					
Voltage (VAC)	90-250	90-250	90-250	90-250	220-250
Frequency (Hz)	47-63	47-63	47-63	47-63	47-63
Power	Single Phase	Single Phase	Single Phase	Single Phase	Single Phase
Ambient ($^{\circ}$ C) ⁽⁷⁾	5-35	5-35	5-35	5-35	5-35
Consumption (W)	<650	<350	<650	<650	<650
PSU Type	LPU350 ⁽⁸⁾	LPU350 ⁽⁸⁾	LPU350 ⁽⁸⁾	LPU350 ⁽⁸⁾	LPU1000 ⁽⁹⁾

All specifications at maximum repetition rate unless otherwise stated.

- (1) Variable by means of Q-switch delay. Energy stability remains within specification from 20% to 100% of output energy. The maximum energy quoted for a system having a 15 minute warm-up period.
- (2) At 1064nm.
- (3) Irreducible beam divergence measured full angle for cone containing 90% of energy.
- (4) Full angle for 99% of shots.
- (5) With the addition of optional removable TEM₀₀ intra-cavity aperture.
- (6) RMS jitter, measured with respect to the Q-switch trigger input.
- (7) 0-80% non condensing input. LPU350R option available as 4U 19" rackmountable PSU.
- (8) LPU350R option available as 4U 19" rackmountable PSU.
- (9) 90-200VAC available on request. LPU1000R option available as 7U 19" rackmountable PSU.

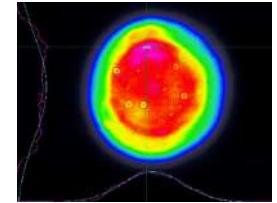

Stable telescopic beam profile, 1064nm near field

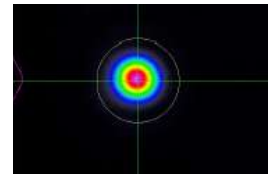

TEM₀₀ beam profile, 1064nm near field

Options

Motorised Optical Attenuator

A motorised optical attenuator allows the user to vary the pulse energy remotely while also maintaining the temporal and spatial profiles of the beam. The pulse energy can be controlled precisely via the software while keeping the beam profile, pulse duration and pulse stability constant.

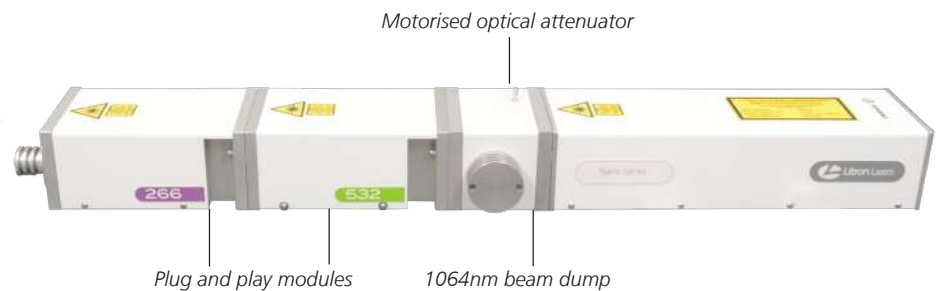

Diode pointer fitted to a 532nm Nano

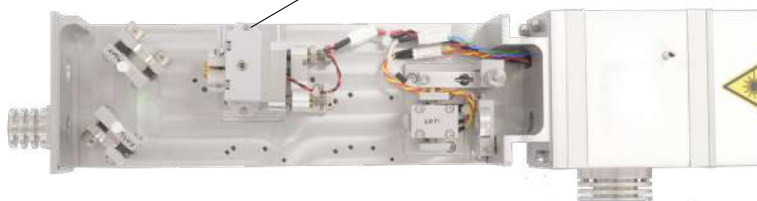

Diode Pointer

Nano series lasers can be specified with a low-power visible CW diode pointer. This is useful for aligning external optics or configuring an experimental setup. The diode pointer should be specified at the time of order.



Nano Series Model Options

Nano flexible output models

Nano lasers give the flexibility to access all the harmonic wavelengths from 1064nm to 266nm by removing and re-combining the appropriate harmonic generation units (HGUs).

All Nano harmonic models are available with the motorised 1064nm variable optical attenuator option fitted.

The model options shown here are available for all Nano S, L and T lasers.

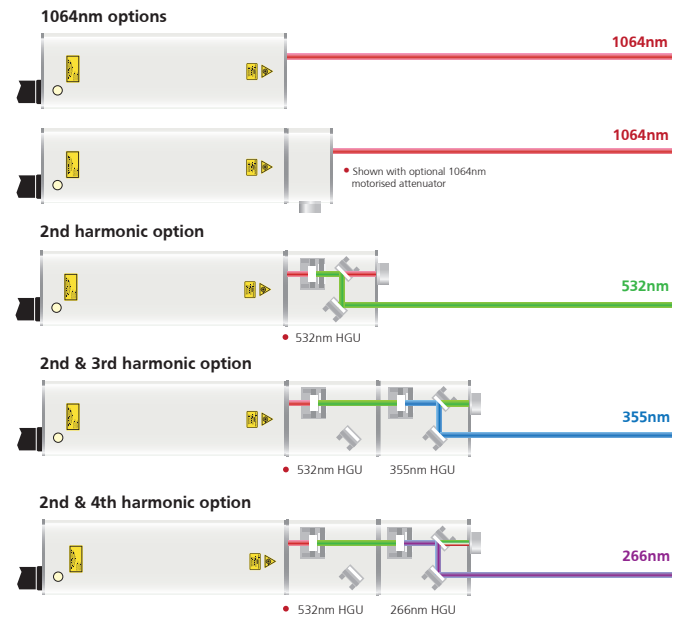

Nano fixed output models

Nano lasers can be offered with fixed output where optimisation of the 1064nm or a single harmonic wavelength is desired.

All Nano harmonic models are available with the motorised 1064nm variable optical attenuator option fitted.

The model options shown here are available for all Nano S, L and T lasers.

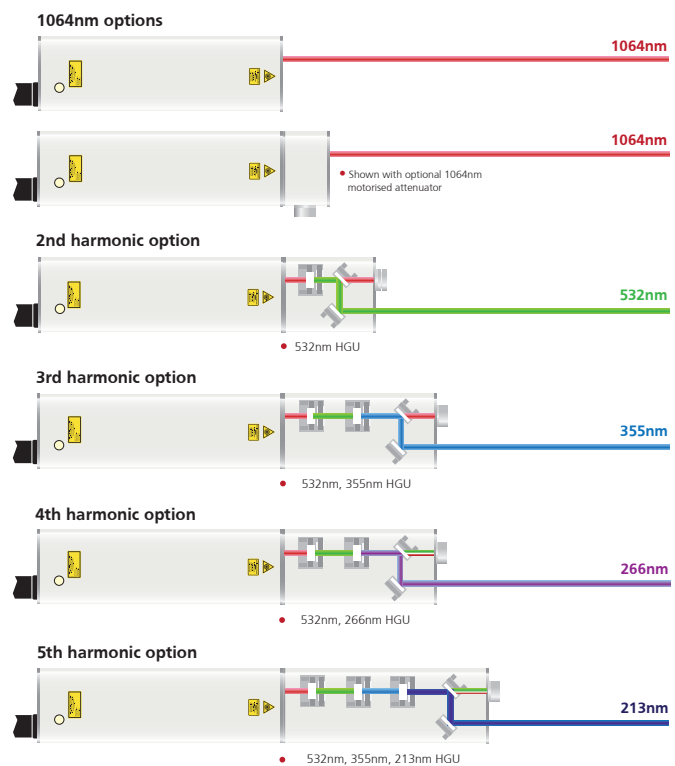

*For details on 213nm, please contact Litron directly

MECHANICAL DATA

All dimensions in mm unless stated.

Nano S Laser Head with 2nd, 3rd/ 4th HGU. (5th HGU length is 265mm. Modular Harmonic length is 145mm.)

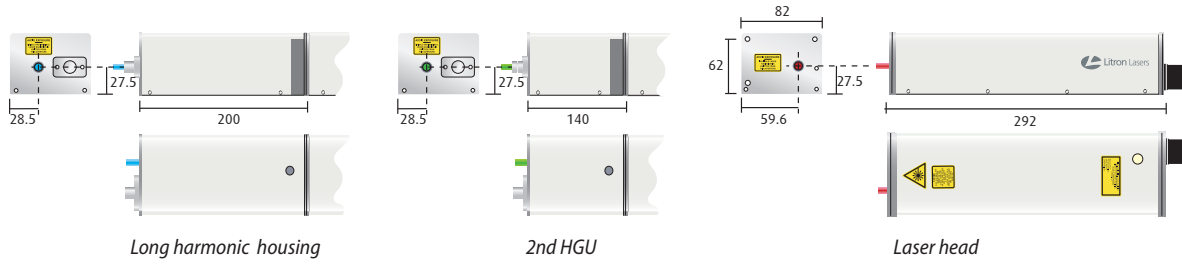

Nano L Laser Head with 2nd, 3rd/ 4th HGU. (5th HGU length is 260mm. Modular Harmonic length is 155mm.)

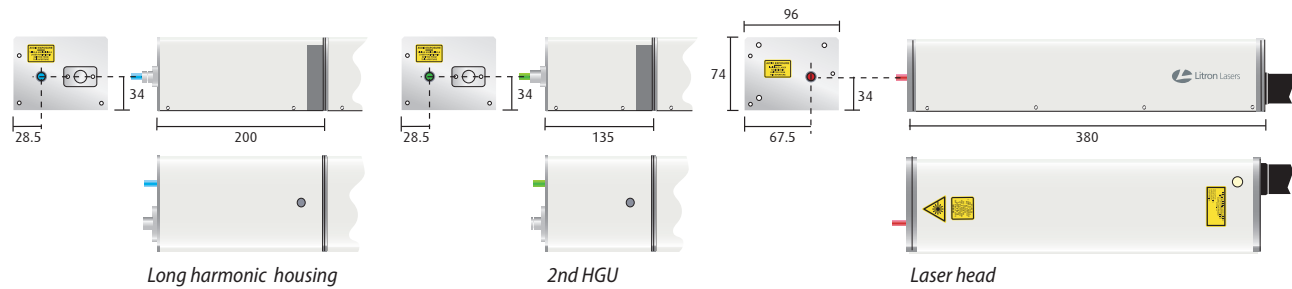

Nano T Laser Head with 2nd, 3rd/ 4th HGU. (5th HGU length is 260mm. Modular Harmonic length is 155mm.)

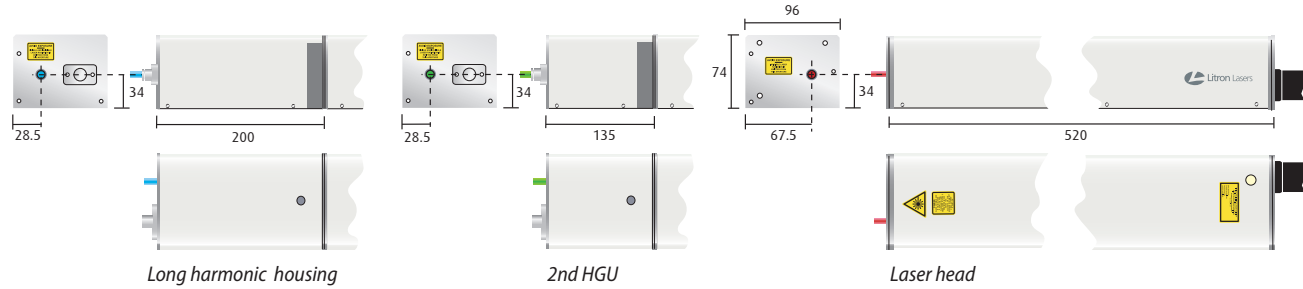

LPU1000 PSU

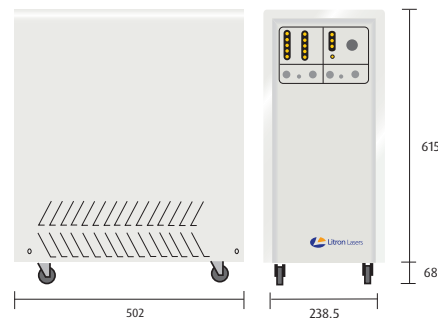

LPU350 PSU

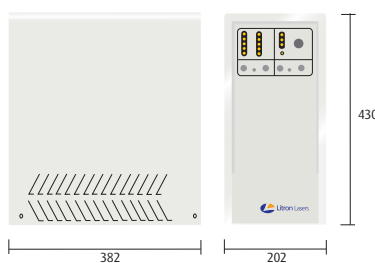

LPU350R PSU

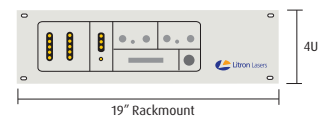

LUCI Touchscreen



Our policy is to improve the design and specification of our products. The details given in this document are not to be regarded as binding.



Litron Lasers Ltd
8 Consul Road, Rugby,
Warwickshire CV21 1PB
England.

T +44 (0)1788 574444
F +44 (0)1788 574888
E sales@litron.co.uk



www.litronlasers.com